

Realization of the Einstein-Podolsky-Rosen Paradox Using Momentum- and Position-Entangled Photons from Spontaneous Parametric Down Conversion

John C. Howell,¹ Ryan S. Bennink,² Sean J. Bentley,^{2,*} and R.W. Boyd²

¹*Department of Physics and Astronomy, University of Rochester, Rochester, New York 14627, USA*

²*The Institute of Optics, University of Rochester, Rochester, New York 14627, USA*

(Received 15 September 2003; published 28 May 2004)

We report on a momentum-position realization of the EPR paradox using direct detection in the near and far fields of the photons emitted by collinear type-II phase-matched parametric down conversion. Using this approach we achieved a measured two-photon momentum-position variance product of $0.01\hbar^2$, which dramatically violates the bounds for the EPR and separability criteria.

DOI: 10.1103/PhysRevLett.92.210403

PACS numbers: 03.65.Ud, 03.65.Ta, 42.50.Xa, 42.65.Lm

In 1935 Einstein, Podolsky, and Rosen (EPR) [1] wrote one of the most controversial and influential papers of the twentieth century. They proposed a *gedanken* experiment involving two particles entangled simultaneously over a continuum of position and momentum states. By measuring either the position or the momentum of one of the particles, either the position or the momentum, respectively, of the other particle could be inferred with complete certainty. EPR argued, on the assumption that distant particles do not interact, that the possibility of making such inferences meant that the position and the momentum of the unmeasured particle were simultaneous realities, in violation of Heisenberg's uncertainty relation. This thought experiment became known as the EPR paradox. In 1951 Bohm [2] cast the EPR paradox into a simpler, discrete form involving spin entanglement of two spin-1/2 particles, such as those produced in the dissociation of a diatomic molecule of zero spin. From Bohm's analysis sprang Bell's inequalities [3,4] and much of what is now the field of discrete quantum information [5–10]. Experimental tests of Bell's inequalities [5] also led to the resolution of the EPR paradox. The standard view is that entangled particles interact nonlocally, in contradiction to EPR's assumption.

In recent years, however, there has been a movement toward the study of entanglement of continuous variables as originally discussed by EPR [11–24]. Of particular interest was the early work of Reid and Drummond [14]. They derived an EPR criterion and showed how it could be implemented with momentumlike and positionlike quadrature observables of squeezed-light fields. Shortly thereafter, the experiment was realized by Ou *et al.* [15]. Later Duan *et al.* [16], Simon [17], and Mancini *et al.* [18] derived necessary and sufficient conditions for the inseparability (entanglement) of continuous-variable states. A flurry of experimental activity ensued in both atomic ensembles [19] and squeezed-light fields [20–22].

Here we report on a demonstration of the EPR paradox using position- and momentum-entangled photon pairs produced by spontaneous parametric down conversion. Transverse correlations from parametric down conversion

have been studied both theoretically [25] and experimentally [26–29]. We find that the position and momentum correlations are strong enough to allow the position or momentum of a photon to be inferred from that of its partner with a product of variances $\leq 0.01\hbar^2$, which violates the separability bound by 2 orders of magnitude. We note that a qualitatively similar result, namely, a violation of a Heisenberg-like uncertainty relation involving photon position and momentum, has been previously reported [30]. That work was an experimental realization of a *gedanken* experiment proposed by Popper. Whereas the EPR experiment concerns the uncertainties Δx_2 and Δp_2 that are conditioned on different measurements (x_1 and p_1 , respectively), Popper's experiment concerns the uncertainties Δx_2 and Δp_2 conditioned on the same measurement (x_1). Nonlocality is relevant in the EPR situation, but not in the Popper experiment. Thus Popper's experiment is fundamentally different than the EPR experiment. Moreover, the existence of flaws in Popper's analysis [31,32] places doubts on the interpretation of his experiment.

In the idealized entangled state proposed by EPR,

$$|\text{EPR}\rangle \equiv \int_{-\infty}^{\infty} |x, x\rangle dx = \int_{-\infty}^{\infty} |p, -p\rangle dp, \quad (1)$$

the positions and momenta of the two particles are perfectly correlated. This state is non-normalizable and cannot be realized in the laboratory. However, the state of the light produced in parametric down conversion can be made to approximate the EPR state under suitable conditions. In parametric down conversion, a pump photon is absorbed by a nonlinear medium and reemitted as two photons (conventionally called signal and idler photons), each with approximately half the energy of the pump photon. Considering only the transverse components, the momentum conservation of the down conversion process requires $\mathbf{p}_1 + \mathbf{p}_2 = \mathbf{p}_p$, where 1, 2, and p refer to the signal, idler, and pump photons, respectively. Provided the uncertainty in the pump transverse momentum is small, the transverse momenta of the signal and idler photons are highly anticorrelated. The exact degree of

correlation depends on the structure of the signal + idler state. In the regime of weak generation, this state has the form

$$|\psi\rangle_{1,2} = |\text{vac}\rangle + \int A(\mathbf{p}_1, \mathbf{p}_2) |\mathbf{p}_1, \mathbf{p}_2\rangle d\mathbf{p}_1 d\mathbf{p}_2, \quad (2)$$

where $|\text{vac}\rangle$ denotes the vacuum state and the two-photon amplitude A is

$$A(\mathbf{p}_1, \mathbf{p}_2) = \chi E_p(\mathbf{p}_1 + \mathbf{p}_2) \frac{\exp(i\Delta k_z L) - 1}{i\Delta k_z}. \quad (3)$$

Here χ is the coefficient of the nonlinear interaction, E_p is the amplitude of the plane-wave component of the pump with transverse momentum $\mathbf{p}_1 + \mathbf{p}_2$, L is the length of the nonlinear medium, and $\Delta k_z = k_{p,z} - k_{1,z} - k_{2,z}$ (where $\mathbf{k} = \mathbf{p}/\hbar$) is the longitudinal wave vector mismatch, which generally increases with transverse momentum and limits the angular spread of signal and idler photons. The vacuum component of the state makes no contribution to photon counting measurements and may be ignored. Also, there is no inherent difference between different transverse components; so without loss of generality, we consider scalar position and momentum. The narrower the angular spectrum of the pump field and the wider the angular spectrum of the generated light, the more closely the integral (2) approximates $\int_{-\infty}^{\infty} \delta(p_1 + p_2) |p_1, p_2\rangle dp_1 dp_2 = |\text{EPR}\rangle$ and the stronger the correlations in position and momentum become.

The experimental setup used to determine position and momentum correlations is portrayed in Fig. 1. The idea is to measure the positions and momenta by measuring the down converted photons in the near and far fields, respectively [24]. The source of entangled photons is spontaneous parametric down conversion generated by pumping a 2 mm thick type-II β -barium-borate (BBO) crystal with a 30 mW, cw, 390 nm laser beam. A prism separates the pump light from the down converted light. The signal and idler photons have orthogonal polarizations and are separated by a polarizing beam splitter. In each arm, the light passes through a narrow 40 μm vertical slit, a 10 nm spectral filter, and a microscope objective. The objective focuses the transmitted light onto a multimode fiber which is coupled to an avalanche photodiode single-photon counting module. The spectral filter ensures that only photons with nearly equal energies are detected. To measure correlations in the positions of the photons, a lens of focal length 100 mm (placed prior to the beam splitter) is used to image the exit face of the crystal onto the planes of the two slits [Fig. 1(a)]. One slit is fixed at the location of peak signal intensity. The other slit is mounted on a translation stage. The photon coincidence rate is then recorded as a function of the displacement of the second slit. To measure correlations in the transverse momenta of the photons, the imaging lens is replaced by two lenses of focal length 100 mm, one in

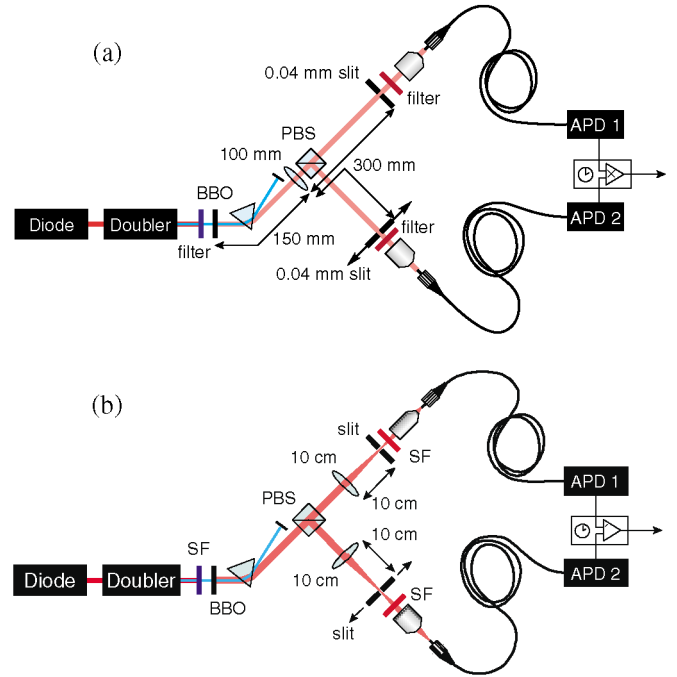

FIG. 1 (color online). Experimental setup for measuring photon correlations. (a) Position correlations are obtained by imaging the birthplace of each photon of a pair onto a separate detector. (b) Correlations in transverse momentum are obtained by imaging the propagation direction of each photon of a pair onto a separate detector.

each arm, a distance f from the planes of the two slits [Fig. 1(b)]. These lenses map transverse momenta to transverse positions, such that a photon with transverse momentum $\hbar k_{\perp}$ comes to a focus at the point $x = f k_{\perp}/k$ in the plane of the slit. Again, one slit is fixed at the location of the peak count rate while the other is translated to obtain the coincidence distribution.

By normalizing the coincidence distributions, we obtain the conditional probability density functions $P(x_2|x_1)$ and $P(p_2|p_1)$ (Fig. 2). These probability densities are then used to calculate the uncertainty in the inferred position or momentum of photon 2 given the position or momentum of photon 1:

$$\Delta x_2^2 = \int x_2^2 P(x_2|x_1) dx_2 - \left(\int x_2 P(x_2|x_1) dx_2 \right)^2, \quad (4)$$

$$\Delta p_2^2 = \int p_2^2 P(p_2|p_1) dp_2 - \left(\int p_2 P(p_2|p_1) dp_2 \right)^2. \quad (5)$$

Because of the finite width of the slits, the raw data in Fig. 2 describe a slightly broader distribution than is associated with the down conversion process itself. By adjusting the computed values of Δx_2 and Δp_2 to account for this broadening (an adjustment smaller than 10%), we obtain the correlation uncertainties $\Delta x_2 = 0.027$ mm and $\Delta p_2 = 3.7\hbar$ mm $^{-1}$. The measured variance product is

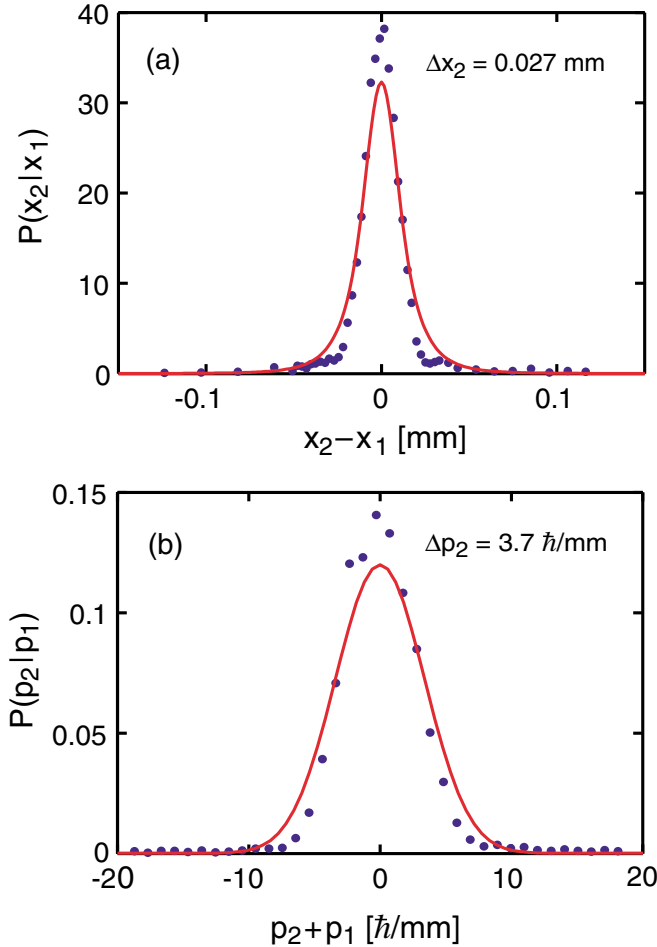

FIG. 2 (color online). (a) The conditional probability distribution of the relative birthplace of the entangled photons. (b) The conditional probability distribution of the relative transverse momentum of the entangled photons. The widths of the distributions determine the uncertainties in inferring the position or the momentum of one photon from that of the other. The solid lines are the theoretical predictions and the dots are the experimental data.

then

$$(\Delta x_2|x_1)^2(\Delta p_2|p_1)^2 = 0.01\hbar^2. \quad (6)$$

We write $\Delta x_2|x_1$ to denote the uncertainty of x_2 conditioned upon measurement of x_1 . We use this notation in order to prevent confusion with similar Heisenberg-like relations.

Also shown in Fig. 2 are the predicted probability densities. These curves contain no free parameters and are obtained directly from the two-photon amplitude $A(p_1, p_2)$, which is determined by the optical properties of BBO and the measured profile of the pump beam. Figure 2 indicates that the correlation widths we obtained are intrinsic to the down conversion process and are limited only by the degree to which it deviates from the idealized EPR state (1). The value of $\Delta(p_2 + p_1)$ is limi-

ted by the finite width of the pump beam. The pump photons in a Gaussian beam of width w have an uncertainty $\hbar/2w$ in transverse momentum which, due to conservation of momentum, is imparted to the total momentum $p_1 + p_2$ of the signal and idler photons. The value of $\Delta(x_2 - x_1)$ is limited by the range of angles over which the crystal generates signal and idler photons. If the angular width of emission is $\Delta\phi$, then the principle of diffraction indicates that the photons cannot have a smaller transverse dimension than $\sim(k_{s,i}\Delta\phi)^{-1}$. Careful analysis based on the angular distribution of emission yields $\Delta(x_2 - x_1) = 1.88(k_{s,i}\Delta\phi)^{-1}$. With the measured beam width of $w = 0.17$ mm and predicted angular width 0.012 rad, the theory predicts $(\Delta x_2|x_1)^2(\Delta p_2|p_1)^2 = 0.0036\hbar^2$. This is somewhat smaller than the experimentally calculated value of $0.01\hbar^2$, even though the data appear to closely match the theoretical curves. The reason for this discrepancy is that the experimental distributions have small ($\approx 1\%$ of the peak) but very broad wings. The origin of these coincidence counts is unknown; they are perhaps due to scattering from optical components. If these counts are treated as a noise background and subtracted, the experimentally obtained uncertainties come into agreement with the theoretically predicted values, yielding an uncertainty product of $0.004\hbar^2$.

To interpret these results, it is helpful to consider the relationship between the original EPR paradox and the issues of entanglement, nonlocality, and quantum signatures, which have been the subjects of more modern studies. The intent of EPR was not to reveal a discrepancy between classical and quantum theory, but to show that quantum mechanics is “incomplete” in the sense that noncommuting observables such as x_2 and p_2 could be known with more certainty than is allowed by the uncertainty principle $(\Delta x_2)^2(\Delta p_2)^2 \geq \hbar^2/4$. As this apparent conflict occurs only for entangled (nonseparable) states, a number of different separability criteria have been developed over the years. Of particular relevance to the original EPR paradox are the tests for separability of continuous-variable systems [16–18]. The tests in [16,17] involve sums of dimensionless variances and are not scale invariant; hence it is not clear how they may be applied to the present EPR experiment involving dimensional position and momentum. The criterion derived by Mancini *et al.* [18] is more useful here. It states that separable systems satisfy the joint uncertainty product $[\Delta(x_2 - x_1)]^2[\Delta(p_2 + p_1)]^2 \geq \hbar^2$, where the uncertainties are calculated over the joint probability distributions $P(x_1, x_2)$ and $P(p_1, p_2)$, respectively. In our experiments the widths of the conditional probability distributions $P(x_2|x_1)$ and $P(p_2|p_1)$ are essentially independent of x_1 and p_1 over their ranges, so that $\Delta x_2|x_1$ and $\Delta p_2|p_1$ are nearly equal to $[\Delta(x_2 - x_1)]^2$ and $[\Delta(p_2 + p_1)]^2$. Therefore our results constitute a 2-order-of-magnitude violation of Mancini’s separability criterion as well as a strong violation of EPR’s criterion.

A critical component of the EPR argument was the principle of locality (the idea that distant particles do not interact). Indeed, one may regard the EPR paradox as a statement of the mutual incompatibility of locality, entanglement, and completeness. Experimental tests of Bell's inequalities have indicated that quantum mechanics is complete by ruling out the possibility of hidden variables [3–5]. Therefore it is generally agreed that the assumption of locality is invalid for entangled states: measurement of either particle of an entangled system projects both particles onto a state consistent with the result of measurement, regardless of how far apart the particles are. In the situation proposed by EPR, the position or momentum of the unmeasured particle becomes a reality when, and only when, the corresponding quantity of the other particle is measured. Since only one quantity or the other is measured, the position and the momentum of the unmeasured particle need not be simultaneous realities. In this way the paradox is resolved.

In conclusion, we have reported the experimental realization of Einstein, Podolsky, and Rosen's paradox using momentum-position entangled photons. We have measured position and momentum correlations resulting in a variance product which dramatically violates the original EPR criterion and a modern inseparability criterion. Compared to squeezed-light realizations of the EPR paradox, the momentum-position realization has several attractive features which make it promising for further development. For one, the entanglement is observed using direct photon detection, which is experimentally simpler than homodyne detection. Second, the entanglement does not reside in the photon count, which frees this quantity to be used for postselection. Since the position and momentum measurements involve only those photons that are detected, the measured entanglement is not degraded by optical loss which inevitably occurs in real systems. For both of these reasons, systems with very small values of the joint uncertainty product can be readily achieved in practice. This capability has already been used to achieve near-diffractionless coincidence imaging [33]. We believe that the work presented here sets the stage for many more interesting applications to come.

J.C.H. acknowledges support from the NSF, from Research Corporation, and from University of Rochester. R.W.B. gratefully acknowledges support by ARO under Contract No. DAAD19-01-1-0623 and by ONR under Contract No. N00014-02-1-0797.

*Present address: Blodgett Hall, Department of Physics, Adelphi University, Garden City, NY 11530.

[1] A. Einstein, B. Podolsky, and N. Rosen, *Phys. Rev.* **47**, 777 (1935)

- [2] D. Bohm, *Quantum Theory* (Prentice-Hall, Englewood Cliffs, NJ, 1951), pp. 614–619.
- [3] J. S. Bell, *Physics* (Long Island City, N.Y.) **1**, 195 (1965).
- [4] J. F. Clauser, M. A. Horne, A. Shimony, and R. A. Holt, *Phys. Rev. Lett.* **23**, 880 (1969).
- [5] A. Aspect, P. Grangier, and G. Roger, *Phys. Rev. Lett.* **47**, 460 (1981).
- [6] A. Ekert, *Phys. Rev. Lett.* **67**, 661 (1991).
- [7] D. S. Naik, *Phys. Rev. Lett.* **84**, 4733 (2000).
- [8] T. Jennewein *et al.*, *Phys. Rev. Lett.* **84**, 4729 (2000).
- [9] W. Tittel *et al.*, *Phys. Rev. Lett.* **84**, 4737 (2000).
- [10] D. Bouwmeester *et al.*, *Nature* (London) **390**, 575 (1997).
- [11] J. D. Franson, *Phys. Rev. Lett.* **62**, 2205 (1989).
- [12] P. G. Kwiat *et al.*, *Phys. Rev. A* **41**, 2910 (1990).
- [13] J. G. Rarity and P. R. Tapster, *Phys. Rev. Lett.* **64**, 2495 (1990).
- [14] M. D. Reid and P. D. Drummond, *Phys. Rev. Lett.* **60**, 2731 (1988).
- [15] Z. Y. Ou, S. F. Pereira, H. J. Kimble, and K. C. Peng, *Phys. Rev. Lett.* **68**, 3663 (1992).
- [16] L. M. Duan, G. Giedke, J. I. Cirac, and P. Zoller, *Phys. Rev. Lett.* **84**, 2722 (2000).
- [17] R. Simon, *Phys. Rev. Lett.* **84**, 2726 (2000).
- [18] S. Mancini, V. Giovannetti, D. Vitali, and P. Tombesi, *Phys. Rev. Lett.* **88**, 120401 (2002).
- [19] B. Julsgaard, A. Kozhekin, and E. S. Polzik, *Nature* (London) **413**, 400 (2001).
- [20] Ch. Silberhorn, P. K. Lam, O. Weiss, F. König, N. Korolkova, and G. Leuchs, *Phys. Rev. Lett.* **86**, 4267 (2001).
- [21] W. P. Bowen, N. Treps, R. Schnabel, and P. K. Lam, *Phys. Rev. Lett.* **89**, 253601 (2002); W. P. Bowen, R. Schnabel, and P. K. Lam, *Phys. Rev. Lett.* **90**, 043601 (2003).
- [22] N. Korolkova, G. Leuchs, R. Loudon, T. C. Ralph, and C. Silberhorn, *Phys. Rev. A* **65**, 052306 (2002).
- [23] S. L. Braunstein and H. J. Kimble, *Phys. Rev. Lett.* **80**, 869 (1998).
- [24] A. Gatti, E. Brambilla, and L. A. Lugiato, *Phys. Rev. Lett.* **90**, 133603 (2003).
- [25] C. K. Law and J. H. Eberly, *Phys. Rev. Lett.* **92**, 127903 (2004).
- [26] D. V. Strekalov, A. V. Sergienko, D. N. Klyshko, and Y. H. Shih, *Phys. Rev. Lett.* **74**, 3600 (1995).
- [27] T. B. Pittman, Y. H. Shih, D. V. Strekalov, and A. V. Sergienko, *Phys. Rev. A* **52**, R3429 (1995).
- [28] C. H. Monken, P. H. Souto Ribiero, and S. Padua, *Phys. Rev. A* **57**, 3123 (1998).
- [29] A. F. Abouraddy, M. B. Nasr, B. E. A. Saleh, A. V. Sergienko, and M. C. Teich, *Phys. Rev. A* **63**, 063803 (2001).
- [30] Y. H. Kim and Y. Shih, *Found. Phys.* **29**, 1849 (1999).
- [31] M. J. Collett and R. Loudon, *Nature* (London) **326**, 671 (1987).
- [32] G. C. Ghirardi, *Sneaking a Look at God's Cards* (Princeton University Press, Princeton, NJ, 2004).
- [33] R. S. Bennink, S. J. Bentley, R. W. Boyd, and J. C. Howell, *Phys. Rev. Lett.* **92**, 033601 (2004).